

THE FOLLOWING RULES MUST BE FOLLOWED TO OBTAIN THE MAXIMUM USAGE FROM AURAND CUTTER BUNDLES.

- 1.) Adjust the depth shoe so the cutters, when thrown out by centrifugal force, extend beyond the face of the depth shoe to a depth equal to the accumulation being removed.
- 2.) Use tool in a back and forth motion, never from side to side.
- 3.) Allow tool to come up to speed before applying to a surface and always remove it from the surface before turning it off.
- 4.) Never operate the tool without the depth shoe in place, as this will cause excessive wear to the cutters and possible damage to cutter bundles parts.
- 5.) Improper adjustment to depth shoe will cause cutter bundles parts to show excessive wear before cutters are used up.
- 6.) Apply only enough pressure to assure that depth shoe contact with surface is maintained. If excessive pressure is used to tool will overheat and damage will occur.

90M CUTTER BUNDLES:

2 Per set ---RH shown, LH opposite.

90ME CUTTER BUNDLES:

4 Per set (Not shown)

There are 6 stacks per bundle. Each stack consists of 7 Spacers and 7 Cutters. Stacks are assembled in alternate patterns. See below

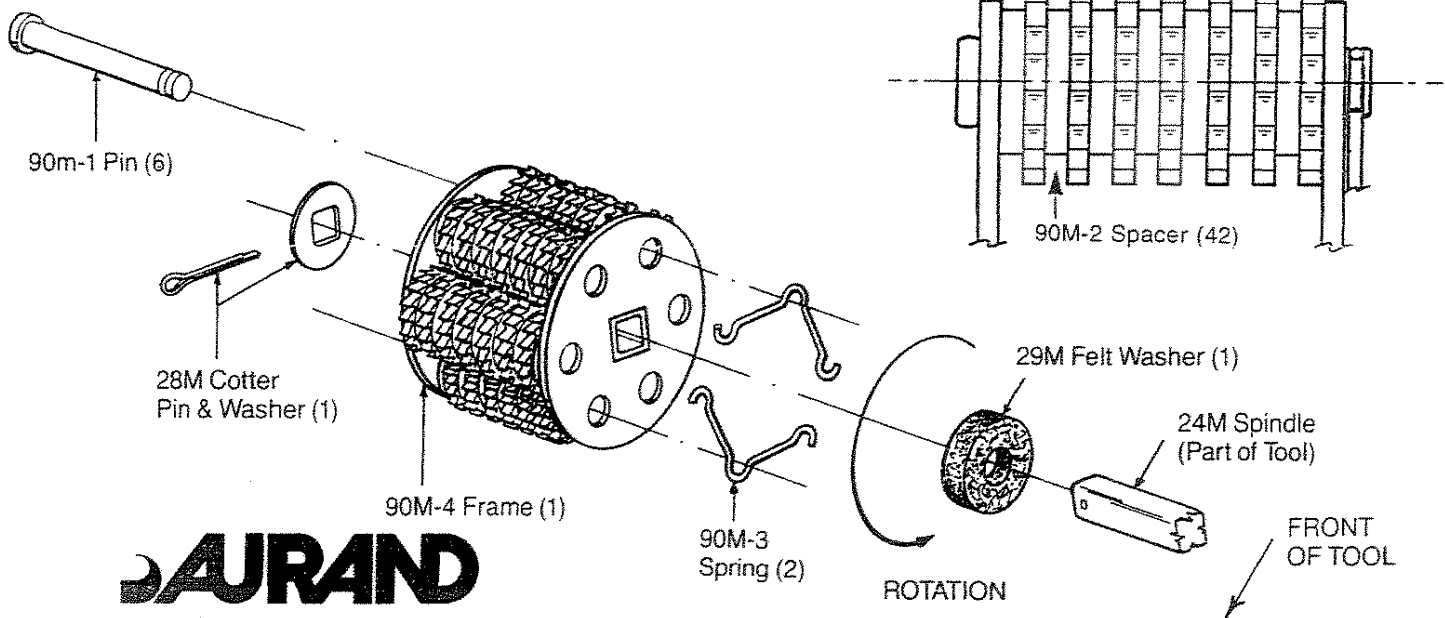

Aurand Manufacturing & Equipment Company
 1210 Ellis Street
 Cincinnati, Ohio 45223-1843
 Phone: 513-541-7200 Fax: 513-541-3065
 Toll Free: 800-860-2872
 Email: sales@aurand.net

